

130° Wild Viewing Angle / Waterproof Camera

Model Number: RH-310W

- ◆ Compact size with waterproof, salt-erosion prevention
- ◆ 130° wide viewing angle (1.65 mm board lens)
- ◆ Employs Digital Signal Processor (DSP) chip-set for image control.
- ◆ High sensitivity, low smear, high anti-blooming, and high S/N ratio.
- ◆ Build-in functions: Auto Electronic Shutter (AES), Auto Gain Control (AGC), Auto White Balance(AWB)
- ◆ Mini Size with 35.5 (W) x 44.65 (D) x 27(H) mm



■ SPECIFICATIONS

Image Pick-up Device	1/4" interline transfer CCD
Effective Picture Elements	NTSC: 510(H)*492(V), PAL: 500(H)*582(V)
Horizontal Resolution	350 horizontal TV lines
Minimum Illumination	1 LUX @ F2.8
S/N Ratio	More than 45 dB
Auto Electronic Shutter	NTSC:1/60s~1/100,000s, PAL:1/50s~1/110,000s
Gain Control	Automatically.
White Balance	Automatically. (2500K~9500K)
Gamma Correct	0.45 / 1 (set to 0.45 before shipment)
Lens Furnished	Board Lens 1.65mm (View Angle: 150 degree)
Synchronous System	Internal, Negative sync.
Video Output	1 Vp-p Composite Video / 75 Ohms.
Power Supply	12V DC / 280 mA
Operating Temp.	-10°C to 50°C (14°F to 122°F)
Water Resistance	IP68
Weight (per unit)	N.W.: 0.135 kg / G.W.: 0.2 kg
Dimensions	35.5(W) x 44.65(D) x 27(H)mm

Design and specifications are subject to change without notice

■ DIMENSION

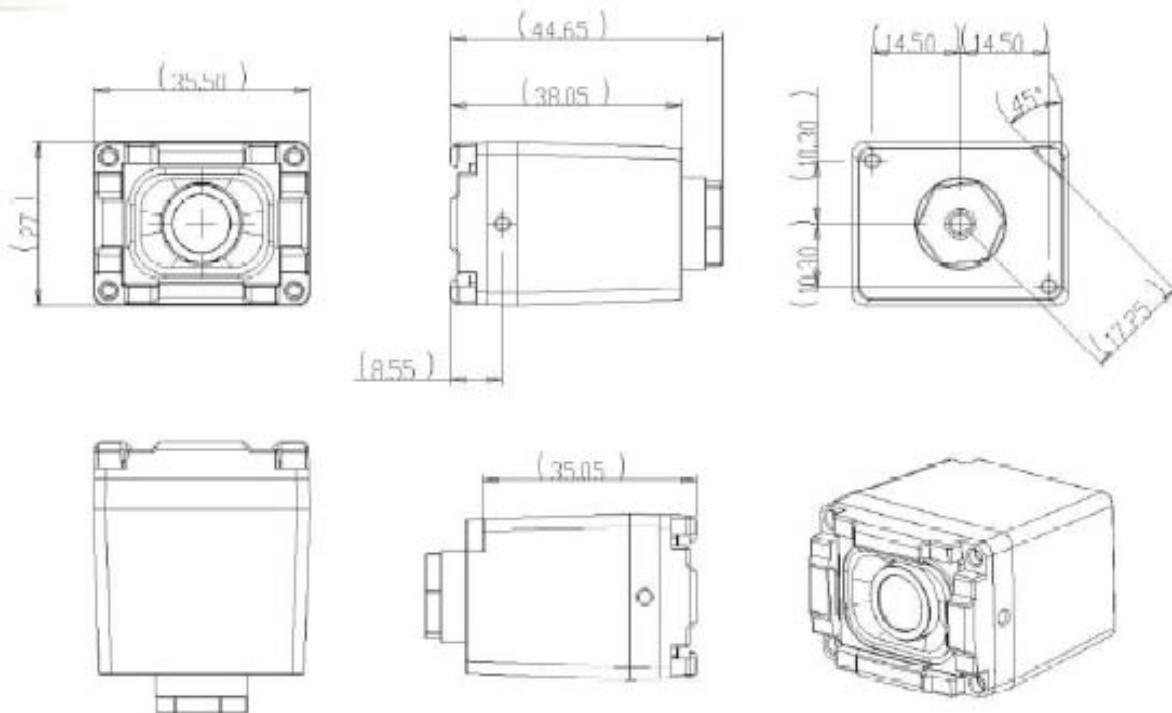

ROCKvision Technology Co., Ltd.

2F-6, No16, Sec 1, Chang-an E,Rd., Taipei City 10442, Taiwan.

Tel: (+886) 2 2523 1120 Fax: (+886) 2 2523 1223

E-mail address : sales@rockvision.com.tw